



EWP Warepads have reduced the excessive wear that the top leaf of the springs and hangers experience from the rough terrain our fleet travels from being in the crude business. Some of our steel pads and leaf springs were being replaced every 8 to 9 months. EWP is lasting at least twice as long, easy to identify during inspections and are easy to install. Our technicians were excited to finally be able to control our extreme suspension wear on our trailers. The many benefits of the EWP Warepads has made it an easy decision to move forward with implementing them into our fleet.

Richard Moss  
Maintenance Director  
EASTEX CRUDE TRUCKING, LLC  
Leesburg, TX



## CORPORATE OFFICE

---

M.C. Tank Transport, Inc., 10134 Mosteller Lane, West Chester, Ohio 45069 • (513) 771-8667 • Fax (513) 771-8825

I've been driving for 37 years and a lease driver to M C Tank Transport Inc. for the last 7 years. When I first saw the EWP warepads being installed on their tank trailers, I laughed. Shortly there after, I pulled one of the trailers they installed them on. Tanks are the most ridged and rough riding trailers you can pull. The difference was unbelievable. Most of them now ride like the air ride trailers. I now stand humbled and baffled.

Sincerely

Chris Gillingham



— PSC METALS, INC. —

We have an abusive type of operation. At times cranes drop whole cars into the trailers and really beat the suspension up. Steel pads wear quickly with that constant friction from the up and down motion. They take time to install and are hard to inspect. By the time you notice the steel pad is missing, the hanger is worn through. And...there is no way to protect the equalizer.

I am glad to say that the EWP Poly Warepads have been in for almost 2 years and are doing great! They help cushion the blow during loading at all 8 contact points and I like the color because they are easy to see during inspections. They are also quicker to install vs. the steel pads.

A handwritten signature in black ink, appearing to read 'Ken Williamson', with a long, sweeping underline.

**Ken Williamson, Shop Foreman**  
PSC Metals, Wooster, OH  
May 2015

# PETERBILT AIR TRAC WAREPAD TESTIMONIAL



Pictured:  
EWP Hanger Poly  
Warepad installed  
over OEM Wear Pad

EWP Warepad is installed over the  
Peterbilt hanger steel pad

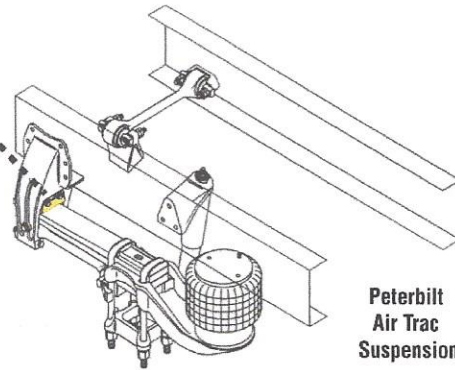

Peterbilt  
Air Trac  
Suspension

From: Kent Harris  
Sent: Tuesday, February 10, 2015 1:37 PM  
Subject: Peterbilt Air Track Ware Pads

Greg,  
I know you've been wanting to hear from me re: Peterbilt Air Trac warepads.

Wound up installing them on worn wear pads. We have probably 14,000 miles on them so far. They're still attached, and there have been no issues. My driver says the truck rides better with them (that part might be in his head, since he knows he's the guinea pig).

But so far I really like the cost. Replacement Flagg wear pads costs \$80.00 plus bolts for each hanger. Peterbilt price lots more.

I'll be ordering more sets for my other trucks.

Thanks!  
Kent Harris  
Kent Harris Trucking, CA

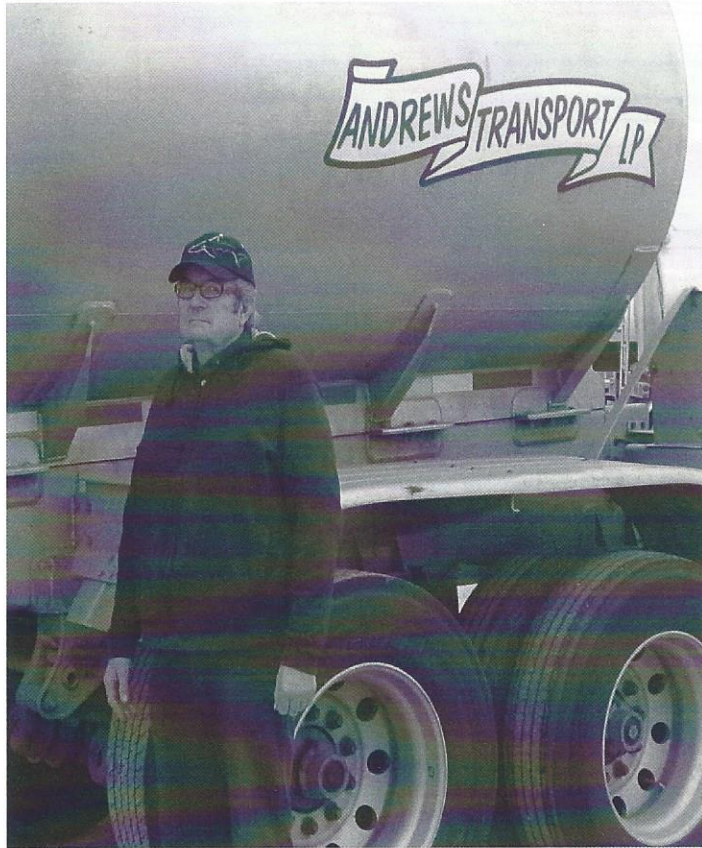

## ANDREWS TRANSPORT, LP

I worked in the shop at Andrews Transport for over 25 years and have been in the equipment maintenance industry for almost half a century. Let's just say I have a lot of experience.

EWP poly pads eliminated that "METAL TO METAL" wear that spring suspensions experience. Before we installed EWP we were replacing our steel wear pads every 6 to 9 months on our jet trailers. That involved de-gassing and down-time. We definitely benefited from the "NO WELD" feature. In addition, the EWP Warepads were lasting up to 5 times longer than the steel pads.

I installed EWP Warepads into Andrew's fleet from 2008 through 2014. I was recently asked, "Do they stay in and are they worth it?" My answer, "This bolted in system not only stays in when installed correctly, but, is an excellent investment. The EWP Warepads lowered our spring breakage by about 95%, and saved fleet maintenance costs, down-time and extended the life of the trailers."

Ron Biggs  
Retired Trailer Shop Foreman  
Andrews Transport, LP  
Fort Worth, TX

## BLUE WATER OIL TRANSPORT, LLC

We have been running the EWP Warepads 7 days a week on our 6 axle trailers that operate around the clock since 2005. We replaced our first Warepad at 450,000 miles which was just over 3 years from time of initial install. During that 3 year period, we estimate that we saved 8 springs, 4 equalizers and 2 hangers per trailer by using the Warepads.

By the way, you know how you get those calls in the middle of the night for a trailer that is down due to spring breakage? Well...we basically have eliminated that from happening! EWP has reduced our spring breakage by 95%.



We feel having the EWP Warepads on our equipment has made us more productive, keeping maintenance costs down and having less downtime resulting in better efficiency for the company. Along with that, our drivers like the quieter ride.

We would like to see our future trailers build from the factory with the EWP Warepads already installed. What a great product for the future of trucking!

Dennis LaFore, Transportation Director  
Jeff Cox, Maintenance Manager  
586-727-4333  
June 2013

Blue Water Oil Transport, LLC  
Richmond, MI 48062

## **PIPER TRUCKING, INC.**

We were just sending this letter to let you know that we are very pleased with the Warepad's that we have installed in both our 11-Axle Dump Trucks and our 8-Axle Flow-Boy trailers. The Warepad's in our opinion have saved us quite a bit on repairs and maintenance with our suspensions. We feel that you have a great product and we have referred you to many of the trucking companies that we work with. We look forward to continuing doing business with you and your company.

Thank you,

Stephen F. Piper  
V. President  
May 10, 2006



---

## **MID THUMB TRUCKING COMPANY**

This product does exactly as advertised. Installation is simple and reduction of noise and wear on suspension parts helps to keep our trucks on the road longer. Since we have fuel tankers, the "no weld" feature is a benefit along with the color of the wear pads. We have had the Propar hanger and equalizer wear pads installed for 18 months now and at about one year we checked the wear. They showed less than 30% wear. At this rate, your product should save my company thousands on maintenance costs.

Sincerely,

George Pfeifauf  
Head Mechanic  
August 24, 2005  
Mid Thumb Trucking Co.