

WAREPAD PART NUMBER: EWP RH2 - INSTALLATION INSTRUCTIONS

RECOMMENDED: Suspension should be in good working condition.

Warepads may be installed on the OEM Hanger while on the trailer frame or off.

TIPS: DO NOT USE PRE-DRILLED OEM HOLES from the manufacturer. See Do's and Don'ts booklet at www.warepad.com for additional tips.

CAUTION: TOP OF WAREPAD MUST BE INSTALLED ON THE AXLE SIDE OF THE HANGER. SEE BELOW FOR DETAILS. INCORRECT INSTALLATION MAY RESULT IN WAREPAD BEING PUSHED OUT BY SPRING.

PREPARATION OF HANGER WITH STEEL PAD:

- A:** When possible, remove existing wear pads, protection products, old existing welds and fasteners
B: If installing Warepads over an existing wear pad, chamfer (sloping edge) and smooth down the edges of steel pad so that there are "NO SHARP EDGES". If Warepad is installed over a sharp object, it may cut the polypad and cause it to be damaged or fall out.
C: If Steel Pads, the thickness of each steel pad in all the hangers must be the same thickness to maintain a level suspension. An unlevel suspension may cause excessive wear to the Warepads.



Attachment Hardware per Warepad:

- 2 - 3/8" Self-Tapping Bolts
- 2 - 3/8" Flat Washers
- 2 - 3/8" Lock Washers

Equipment/Tools Needed for Installation:

- 3/8" Drill Bit
- 1 1/32" Drill Bit
- Drill Motor
- Marking Pen
- 9/16" Open End Box Wrench
- 3/8" Drive Ratchet Wrench
- 3/8" Drive 9/16" Socket
- Red Loctite Series 271

Step 1: Locate top of Warepad. Mark the location as "Top."



Step 2: Examine OEM Hanger. Does the hanger have pre-existing holes from the manufacturer for Warepad attachment?

If YES, use the OEM Hanger pre-existing holes as a guide to mark 3/8" drill hole locations into Warepad. Drill 3/8" drill holes into Warepad at these locations. Skip to step 5.

If NO, go to Step 3.

Step 3A: Use the flat washers as a guide to mark drill location on Warepad.

TOP OF WAREPAD

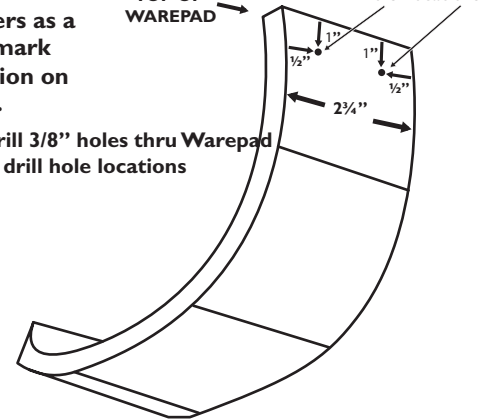

Step 3B: Drill 3/8" holes thru Warepad at drill hole locations

Step 4: Use the drilled Warepad from Step 3 as a guide to mark OEM hanger.

Top of Warepad on axle side of hanger.

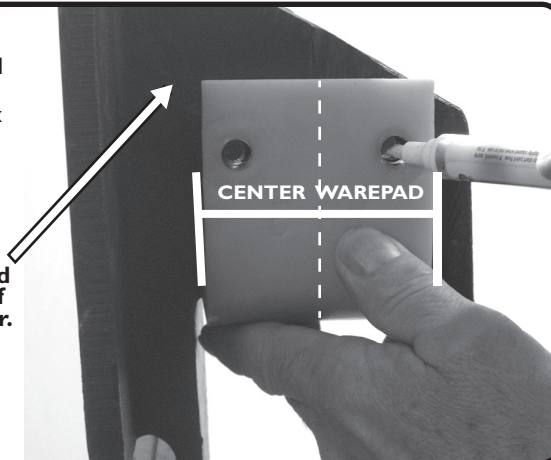

Step 5: Drill 1 1/32" holes into OEM hanger.



Steps 6A-C: FASTENER INSTALLATION/TIGHTENING.

6A: Use Red Loctite Series 271 on the thread of the bolt when installing fasteners.

6B: Install fasteners according to diagram in Step 7.

6C: Bolt Tightness. There is no torque for bolt tightness. Snug the bolt. Bolt tension should be done MANUALLY with a 3/8" Drive Ratchet Wrench, 9/16" Open End Box Wrench and 3/8" Drive 9/16" Socket. Maximum tightening is reached when the Flat Washer presses into the polypad surface to cause a minor indentation. The washer may bend slightly.

CAUTION! DO NOT OVER-TIGHTEN TO CAUSE the washer to invert or buckle.



WAREPAD PART NUMBER: EWP RH2 - INSTALLATION INSTRUCTIONS

Step 7: Place Warepad onto underside of OEM Hanger. Line up holes. Top of Warepad must be on the axle side of Suspension. Install fasteners MANUALLY (Steps 6A-C) with Red Loctite Series 271 on the thread of the bolt. VERY IMPORTANT! See Steps 6A-C for Fastener Installation/Tightening.

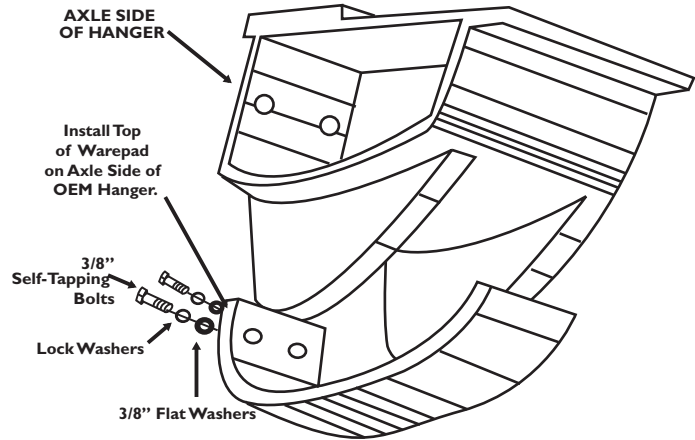

**Pictured:
Hanger
installed with
fasteners**

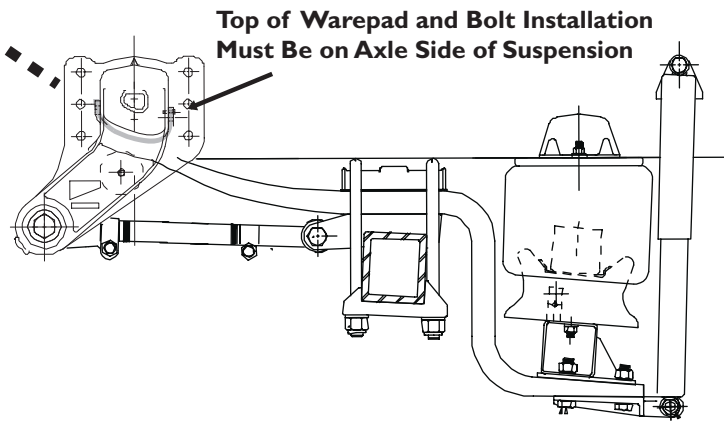

EWP Maintenance Recommendation immediately after installation:

Once the weight of the suspension has been dropped back down upon the axles, it is recommended to re-check the fastener tightness. The weight of the suspension may cause the Warepad to compress.

If the Warepad is loose, re-tighten the fastener MANUALLY with a 3/8" Drive Ratchet Wrench, 9/16" Open End Box Wrench and 3/8" Drive 9/16" Socket so that the Warepad is being held tightly to the hanger by the fastener system. There is no torque for tightness. Maximum tightening is reached when the washer that is directly on the Warepad presses into the polypad surface to cause a minor indentation. The washer may bend slightly. DO NOT OVER-TIGHTEN to cause the washer to invert or buckle.

It is recommended to inspect the Warepads during routine maintenance schedules and during PM's.

For complete Maintenance and Inspection Procedures please check Install Manual or visit: www.warepad.com.